

IMPRESS. INVOLVE. IMPACT.

Rear projection, interactive system

In today's competitive corporate environment we all need to stand out from the crowd. The Inspire interactive rear projection cabinet is a powerful communications tool that will help your organisation project the right image.

As well as its obvious applications in training rooms, it's also designed for boardrooms, meeting rooms and corporate conference venues – environments where first impressions count. It offers all the easy-to-use touch screen functionality and versatility of a front projection interactive whiteboard, but in a more elegant, self-contained package. This makes the system ideal for special needs classrooms.

The fact that it's self-contained, makes it a versatile and flexible tool in public access areas, too – like retail outlets, corporate lobbies and public information kiosks.

- Simple plug-and play, set up and operation
- Touch screen functionality makes it easy to select, and navigate between, attached computer applications and multimedia sources – all from one location
- Save time and travel costs by interacting with multiple locations remotely
- Build it into a wall or use as a free-standing, wheel-around unit. Fits through standard single doorways
- Fantastic image quality with no shadows – wherever the presenter is standing. The mobile system comes complete with top quality SVGA or XGA projector
- Enables annotation over computer files and images; simply edit and save the notes you make, then print them out or email them for further assimilation
- Comes complete with new powerful Interact Software – feature rich annotation and presentation software to enhance learning or meetings



Impress

Sophisticated, slim-line and stylish, the Inspire rear projection interactive screen is the ultimate presentation tool for professionals. It looks elegant when built into the wall of a boardroom or conference centre meeting room. And, with advanced optical characteristics, the image quality it delivers is stunning, too.

Because the multimedia projector is positioned behind the screen, the key advantage it has over a front-projection system is no shadows are cast over the screen – even when the presenter is stood directly in front of it. And, whether it's built-in or mounted on a mobile cabinet, everything – from the projector and computer to additional multimedia sources – can be hidden away, for a neat, secure and professional appearance.

Involve

Whether via the Internet or an organisation's intranet, used in conjunction with videoconferencing applications, the Inspire interactive screen enables you to interact with colleagues, suppliers and prospective clients in multiple remote locations – saving you time and travel costs. This makes it a great tool for collaborative projects. Team members can be in the same room or in various locations around the world and all be able to contribute, interacting with the same applications, images and notes.

Beyond enabling more effective and professional presentations, training and education, the Inspire rear projection interactive whiteboard is also a flexible and versatile tool in public access environments. Whether used to deliver an interactive presentation in retail outlets and corporate lobbies or integrated within a public information kiosk, touch screen functionality engages people directly.

Impact

Make your point with maximum impact. Capture and hold the attention of your audience by seamlessly integrating a range of stimulating multimedia sources into your presentations using Interact. From content rich computer applications and websites to TV, DVD and video, the Inspire interactive screen delivers superb, high-quality images for a truly immersive visual experience. Plus, because you control it all from the screen at the front of the room, it's easier to keep everyone focused.

An Inspire rear projection interactive screen will change the way you share and use information. If you want to highlight a key point or make notes, simply write on it as you would on a normal screen – even over computer-generated imagery – except, with this versatile tool, any notes and diagrams made on screen can be saved for further assimilation at a later date. It couldn't be easier.

Technical Specifications - Inspire Rear Projection Interactive Screen

Model	W x H x D (mm)	Active area (diagonal)	Weight
RP360	1317 x 1012 x 66	60" (1524mm)	25Kg
RP360M	1410 x 1900 x 700	60" (1524mm)	127Kg
RP370	1520 x 1163 x 66	70" (1778mm)	30Kg
RP380	1723 x 1314 x 66	80" (2032mm)	35Kg

Warranty:

3 year return to base, upgradeable to onsite (UK)

Windows operating systems:

Pentium® 150 MHz processor (Pentium II processor or later recommended)

32 MB of RAM (128MB Recommended)

Windows 98SE, Windows NT® 4.0 (SP-6) operating system or later recommended

210 MB of free hard disk space for complete installation of Interact Software and business or education clipart

Colour:

Graphite Grey (Light Maple wood for RP360M)

Cable Length:

5m USB (extendible to 25m using USB cable repeaters)

Power Supply:

Simply connect to your computer via USB or serial. It uses less than 5mA via the connection

Other Features:

Interact Software – Windows

UPDD Drivers – Windows, Macintosh OSX and Linux

Manufactured in the UK

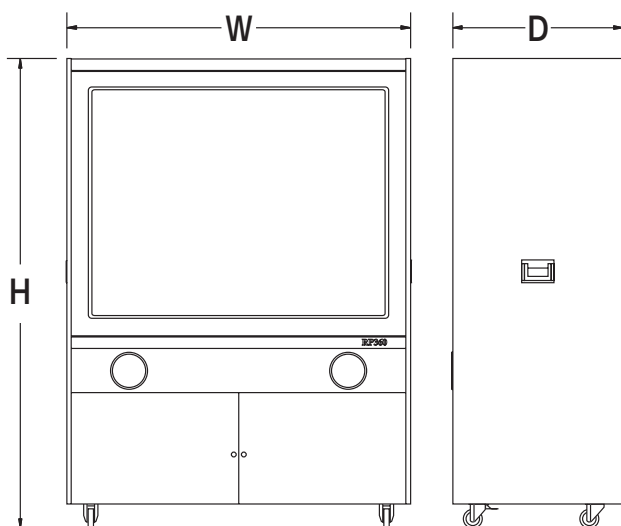

RP360M

ITL reserve the right to change the product specifications without notice

interactive technologies[®]

Interactive Technologies Limited

Unit 14 · Moorbrook Park · Didcot · Oxfordshire · OX11 7HP · United Kingdom

Main +44 (1235) 516900 Fax +44 (1235) 516910

Sales +44 (1235) 516920 Email info@itdisplays.com

Tech +44 (1235) 516930

www.itdisplays.com